

1968-69 FORD (AUTOLITE) SINGLE BARREL MODELS 1100 & 1101

FORD MODEL 1100

1968 Comet, Falcon, Fairlane, Montego & Mustang 200" 6 Cyl.	① Ford Carburetor No. Synchro-mesh Auto. Trans. C80F-A	C80F-B
---	--	--------

1969 Falcon & Mustang 200" 6 Cyl.	C9DF-B	C80F-B
---	--------------	--------

① - Carburetor part number prefix and suffix as stamped on carburetor. Basic part number (9510) omitted.

FORD MODEL 1101

1968 Ford 240" 6 Cyl.	① Ford Carburetor No. Synchro-mesh Auto. Trans. C8AF-E	C8AF-E
-------------------------------	--	--------

1969 Ford & Meteor Police & Taxicab 240" 6 Cyl.	②	C8AF-E
--	---------	--------

1969 Falcon, Fairlane, Montego & Mustang 250" 6 Cyl. (No Air Cond.)..	C90F-B	C90F-A
(With Air Cond.),	C90F-J	C90F-K

① - Carburetor part number prefix and suffix as stamped on carburetor. Basic part number (9510) omitted.
② - Carter YF Carburetor used on this model.

► CHANGES, CAUTIONS, CORRECTIONS

► **IMCO & THERMACTOR ENGINE NOTE:** These engines have special exhaust emission controls as follows: **All Engines** - Specially calibrated carburetor and distributor, closed positive crankcase ventilation system and distributor vacuum advance control valve to advance timing during deceleration. **Thermactor Engines** - Also have air pump for air injection in engine at exhaust valve ports.

CARBURETOR IDENTIFICATION

Carburetor number Prefix and Suffix (Example C5DF L) is stamped on tag attached to carburetor by one air horn screw. First letter on second line on tag ("A" etc.) indicates design changes which may affect parts replacement (other letters on this line are assembly code designating time of manufacture).

DESCRIPTION

Single barrel downdraft type with automatic choke. Carburetors are same design used on corresponding previous models and are alike except for automatic choke and fast idle mechanism. Model 1100 carburetors have torsion spring type automatic choke (no vacuum piston) and "internal type" dashpot. Model 1101 carburetors have vacuum piston type automatic choke and "external type" dashpot. These carburetors are adjusted differently. See *Adjustment*.

Idle Limiter Cap - Idle mixture adjusting screw has idle limiter cap installed on screw which limits range of adjustment for exhaust emission control. *Do not remove or deform limiter cap and make certain ear on cap contacts stop on carburetor body to provide positive stops for mixture screw adjustment range.*

Solenoid Throttle Modulator - Used on Model 1101 carburetors with Air Conditioning. Consists of a solenoid operated plunger controlling engine idling speed. When ignition turned off, regular throttle stopscrew allows throttle valve to close further. Requires special idle speed adjustment procedure. See *Adjustments*.

ADJUSTMENT

NOTE - Before making idle speed and mixture adjustment, turn idle mixture screw counterclockwise to limit of travel with limiter cap ear against stop on carburetor body. Stabilize engine and underhood temperature by running engine for minimum of 20 minutes at 1500 RPM. Make adjustments as follows:

Idle Speed & Mixture

With engine at normal operating temperature (choke valve wide open and fast idle inoperative), place transmission selector lever in Drive, turn on headlights (to place alternator under load, turn Air Conditioner Off (if used), make certain that air cleaner installed (if necessary to remove air cleaner for adjustment, final idle speed and mixture setting must be made with air cleaner installed). Adjust each engine as follows:

Carburetors without Solenoid Throttle Modulator - Adjust throttle stopscrew for correct hot engine idle speed (see Specifications), turn idle mixture screw in (clockwise) for smoothest possible idle within range of adjusting screw limiter. Recheck idle speed and repeat idle mixture adjustment if necessary.

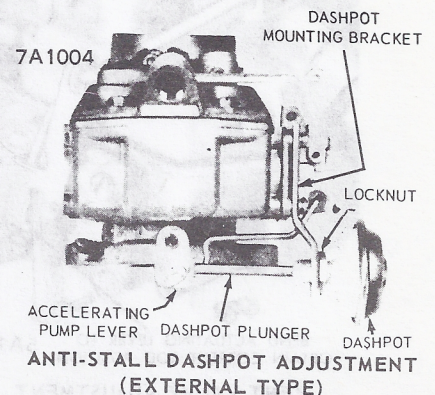
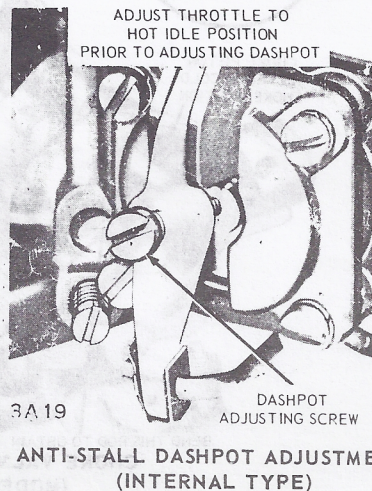
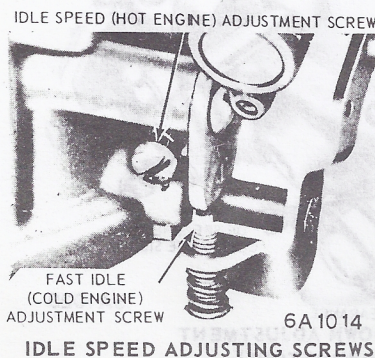

Ford Carburetors

1968-69 FORD (AUTOLITE) SINGLE BARREL MODELS 1100 & 1101 (Continued)

Carburetors with Solenoid Throttle Modulator - Loosen solenoid mounting locknut and turn solenoid in or out of bracket for correct hot engine idle speed (Higher speed as listed in Specifications). *NOTE - Solenoid must be energized (lead connected and ignition ON).* Turn idle mixture screw in (clockwise) for smoothest possible idle within range of adjusting screw limiter. Recheck idle speed and repeat idle mixture adjustment if necessary. Then disconnect solenoid lead (throttle valve will close further) and adjust throttle stopscrew for correct idle speed (Lower speed as listed in Specifications). Reconnect solenoid lead, open throttle valve slightly by hand. Solenoid plunger should follow throttle lever and increase idle speed to "solenoid energized" specification.

lever. If clearance not correct (see Specifications), adjust by loosening lockout and turning dashpot in or out of mounting bracket.

Mike's Carburetor Parts

SPECIFIED SIZE Drill OR Gauge BETWEEN CHOKE PLATE AND UPPER BODY. ADJUST PLASTIC NUT TO JUST CONTACT SWIVEL

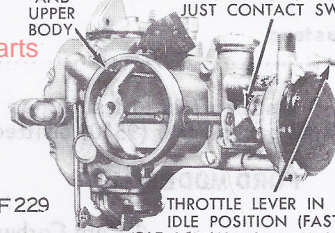

3F229

THROTTLE LEVER IN FAST IDLE POSITION (FAST IDLE SCREW AGAINST COLD POSITION ON FAST IDLE CAM)

CHOKE VALVE PULL-DOWN ADJUSTMENT (MODEL 1100 CARBURETORS)

Fast Idle Speed

With engine at normal operating temperature and idling, manually rotate fast idle cam until fast idle adjusting screw is positioned on center step of cam, turn fast idle adjusting screw in or out for correct fast idle speed (see Specifications).

Throttle Linkage (Auto. Trans. Cars)

See CARBURETOR on car model Tune-Up pages.

Anti-Stall Dashpot

NOTE - Dashpot not used on carburetors with Solenoid Throttle Modulator.

Internal Type - With throttle valves in normal (hot idle) position, turn dashpot adjusting screw (see illustration) until it just contacts dashpot plunger assembly, then turn adjusting screw in against plunger assembly the correct number of additional turns (see Specifications).

External Type - With idle speed correctly adjusted, close throttle valve fully, fully depress dashpot plunger and check clearance between dashpot plunger tip and throttle

Accelerating Pump Lever (Model 1100 Carburetors)

Make certain roll pin installed in lower "HI" position in pump lever (see illustration) and see that throttle valve

WITH THROTTLE PLATE FULLY CLOSED, INSERT A Drill or Gauge OF THE SPECIFIED CLEARANCE DIMENSION BETWEEN THE PIN AND COVER

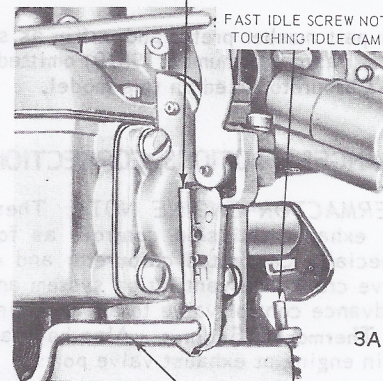

3A18

BEND ROD TO OBTAIN SPECIFIED CLEARANCE

ACCELERATING PUMP ADJUSTMENT

NOTCH ON VENT VALVE ROD TO ALIGN WITH EDGE OF HOLE, WITH THROTTLE IN HOT IDLE POSITION

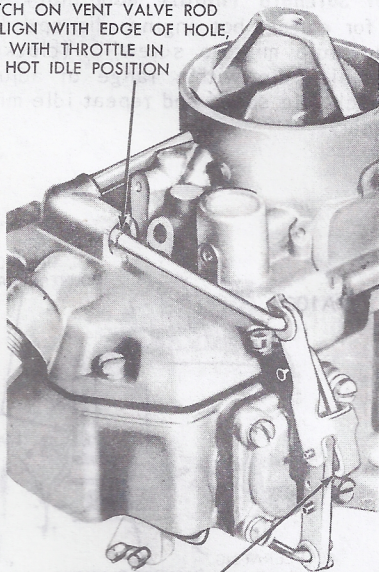

BEND ACTUATING LEVER TO OBTAIN CORRECT ROD POSITION 5A1028

VENT VALVE ADJUSTMENT

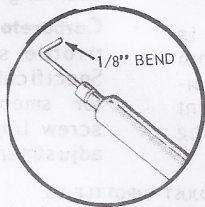

CHOKE PISTON LEVER IN COLD CHOKE POSITION

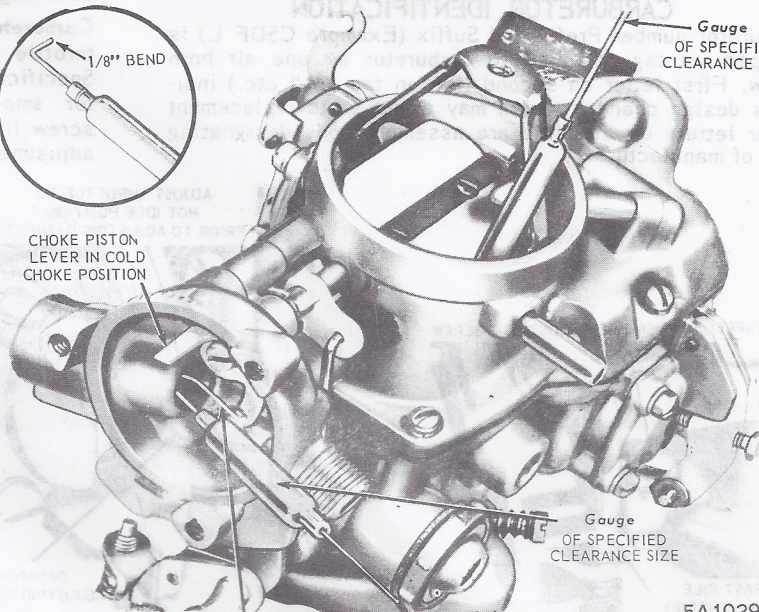

Gauge OF SPECIFIED CLEARANCE SIZE

Gauge OF SPECIFIED CLEARANCE SIZE

BEND THIS ROD TO OBTAIN SPECIFIED CLEARANCE

CHOKE VALVE PULL-DOWN ADJUSTMENT (MODEL 1101 CARBURETORS)

5A1029

1968-69 FORD (AUTOLITE) SINGLE BARREL MODELS 1100 & 1101 (Continued)

completely closed. Insert gauge or drill rod of specified size (see "Specifications"), between roll pin and pump cover surface. Bend pump actuating rod as necessary to obtain this clearance between roll pin and pump cover. Then adjust vent valve.

Pump Setting - Pump lever has two holes ("HI" - lower hole, "LO" - upper hole) but specified setting as listed below has been selected for exhaust emission control and setting should not be changed.

Pump Setting

C8AF-E, C80F-A, C80F-B, C9DF-B HI
All Others No Adjustment

Vent Valve

Adjust after accelerating pump adjustment completed. With throttle linkage in hot idle position, groove in vent valve rod should be even with edge of vent valve housing (see illustration). Adjust by bending arm on vent valve operating lever at point where it contacts accelerating pump lever.

Choke Valve Pull-down

Model 1100 Carburetors - 1968 carburetors require that this adjustment be made with the carburetor OFF the engine and includes Fast Idle Cam Linkage adjustment as a preliminary step. Insert a .020" gauge pin or drill between throttle valve and side of throttle bore and close throttle valve against the gauge, hold choke valve closed and turn fast idle screw in until it just contacts fast idle cam. Place gauge pin or drill of correct size (see Specifications) between edge of choke valve and air horn wall and close choke valve against this gauge. Close throttle valve until fast idle screw just contacts fast idle cam and adjust plastic nut (behind choke housing) to just contact swivel on choke lever assembly.

1969 Carburetors require that this adjustment be made after fast idle speed adjustment has been completed. Remove air cleaner and position fast idle adjusting screw on **Highest** step of fast idle cam (screw must remain in this position while making following adjustment). Insert gauge pin or drill of specified size (see Specifications) between lower edge of choke valve and air horn wall, hold choke valve against gauge and adjust plastic nut on choke pull-down rod until it contacts the swivel on the choke lever assembly.

Model 1101 Carburetors - Remove choke cover and thermo-static coil assembly, block the throttle valve half-open so that fast idle screw does not contact fast idle cam. Bend a .036" wire gauge at a 90° angle approximately 1/8" from end and insert bent end between lower edge of choke piston slot and upper edge of right hand slot in choke housing (see illustration). Move piston lever counter-clockwise until gauge is snug in slot and hold gauge in place by light pressure on lever. Insert gauge or drill rod of correct size (see "Specifications") between front edge of choke valve and air horn wall, carefully bend choke piston link until choke valve clearance is correct.

Automatic Choke

After completing the choke valve pull-down adjustment (above), loosen automatic choke cover retaining screws, rotate cover and coil assembly to align index mark on cover with correct graduation of scale on housing (see "Specifications"), tighten cover screws. **NOTE** - If carburetor on engine, coolant hose and bracket must be removed from carburetor before making automatic choke adjustment.

CARBURETOR ADJUSTMENT SPECIFICATIONS								
Ford Carb. Number	Idle Speed (Engine RPM)		Float ⑤ Setting	Auto. Choke Setting	Choke Valve Pull-down		Dashpot Setting	Accel. Pump Lever
	Hot	Fast ②			Choke Valve	Throttle Valve		
C8AF-E ③	500 ①	1600	1 3/32"	3 Lean	.200" ⑥	.036" ③	.080"	.190"
C80F-A	700 ①	1400	1 3/32"	2 Lean	.150"	.020"	3 Turns	.190"
C80F-B ③	550 ①	1500	1 3/32"	1 Lean	.130" ⑥	.020"	2 Turns	.190"
C8AF-E	500 ②	1600	1 3/32"	3 Lean	.200"	.036"	.080"	.190"
C80F-B ③	550 ②	1500	1 3/32"	1 Lean	.130"	-	2 Turns ⑦	.190"
C9DF-B	750 ②	1400	1 3/32"	3 Lean	.150" ⑥	-	3 Turns ⑦	.150"
C90F-A	550 ②	1600	1 3/32"	3 Lean	.200" ⑥	.036" ③	.080"	.190"
C90F-B	700 ②	1400	1 3/32"	1 Lean	.200" ⑥	.036" ③	.080"	.190"
C90F-J	④②	1400	1 3/32"	1 Lean	.200" ⑥	.036" ③	None	.190"
C90F-K	⑤②	1600	1 3/32"	3 Lean	.200" ⑥	.036" ③	None	.190"

- ① - Auto. Trans. in DRIVE; Air Cond. ON; Headlights on High Beam.
- ② - Fast idle screw on CENTER step of fast idle cam.
- ③ - Choke piston gauge.
- ④ - 700 RPM (solenoid energized), 500 RPM (solenoid disconnected).
- ⑤ - 550 RPM (solenoid energized), 450 RPM (solenoid disconnected).
- ⑥ - Plus or minus .010".
- ⑦ - Plus or minus 1/4 turn.
- ⑧ - 1968-69 Carburetors, numbers used both years.
- ⑨ - Auto. Trans. in DRIVE; Air Cond. OFF; Headlights on High Beam.

1968-69 FORD (AUTOLITE) SINGLE BARREL MODELS 1100 & 1101 (Continued)

Float Level

With upper body assembly removed from carburetor, remove gasket and invert assembly. Measure distance from gasket surface of upper body to top of float (see illustration). If this distance not correct (see "Specifications"), adjust by bending float arm tab. **CAUTION - Do not apply pressure on float inlet needle valve which may damage Viton needle tip and cause a false setting.**

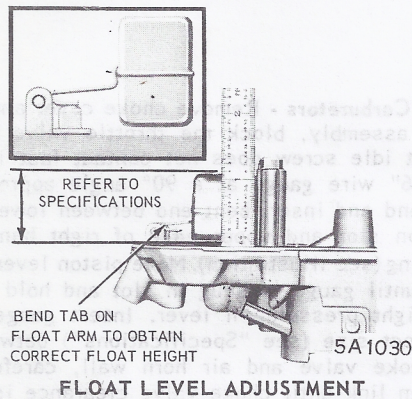

OVERHAUL

Disassembly

Automatic Choke - Disassemble each type automatic choke as follows:

Ford Model 1100 - Disconnect choke pull-down rod from throttle lever. Remove choke thermostatic spring housing retaining screws, remove clamp, thermostatic spring housing, and gasket. Remove choke housing-to-lower body retaining screws, rotate housing to disconnect choke control rod and remove housing and gasket. Remove choke control lever-to-thermostatic choke shaft screw and remove choke control lever assembly and spring. Slide choke shaft out of choke housing. Remove choke control rod from lever, remove choke pull-down rod adjusting nut and slide rod out of swivel.

Ford Model 1101 - Remove choke thermostatic spring housing retaining screws, remove clamp, thermostatic spring housing, and gasket. Remove choke housing-to-upper body retaining screws, remove choke housing assembly and gasket. Remove choke shaft retaining screw and washer (within housing), remove choke shaft and retainer assembly and lever, link, and piston assembly from housing. Remove fast idle cam mounting screw, remove fast idle cam and lever assembly.

Carburetor - Disassemble each type carburetor as follows:

Ford Model 1100 - Squeeze tank on fuel bowl vent valve rod to accelerating pump vent actuating lever and disconnect vent rod from lever. Remove rod and spring. Separate upper and lower body.

Ford Model 1101 - Separate upper and lower body by tilting fuel bowl vent side of upper body to allow clearance, then disconnect fuel vent valve rod from actuating lever on accelerating pump. Remove rod and spring.

All Models - 1) Invert lower body assembly to allow accelerating pump discharge weight and ball check, inlet ball check, and dashpot ball check to fall out into hand.

2) Remove float retaining pin and float assembly, needle valve and seat. Remove main jet, then remove roll pins securing air cleaner bracket to air horn. **NOTE - Use pliers and rotate roll pins in a direction that will coil the pins to a smaller diameter.** Pull air cleaner bracket out of channels.

3) If necessary to remove choke valve and shaft, lightly scribe choke valve along shaft so that choke valve can be installed in same position during installation. Remove valve attaching screws and remove valve from top of air horn by sliding plate out of shaft. Remove shaft from air horn.

4) Depress tab on accelerating pump link to control rod retaining clip and slide rod from link. Remove accelerating pump cover screws and remove cover assembly. Separate pump diaphragm and spring from cover or body.

5) If necessary, remove fuel vent rod actuating lever-to-cover retaining pin and accelerating pump lever-to-cover retaining pin. Remove lever and rod from cover.

6) If carburetor is equipped with internal type dashpot, remove dashpot cover assembly and remove the diaphragm and spring from cover or body. Disconnect rod from dashpot lever. If necessary, remove lever-to-cover pin and remove lever from cover.

7) Remove throttle shaft retaining ring, accelerating pump lever and overtravel spring from throttle shaft. Remove accelerator pump and dashpot control rods from lever.

8) Remove the vacuum outlet adapter. If necessary to remove throttle valve and shaft, scribe a light line along valve shaft so throttle valve can be installed in same position, then remove valve retaining screws and slide valve out of shaft. **NOTE - Retaining screws are staked to shaft. If necessary, file off flared end of screws.** Remove overtravel spring tension pin from throttle shaft and slide shaft out of body.

Cleaning & Inspection

CAUTION - Accelerating pump diaphragm, power valve, and dashpot assembly are not cleaned in solvent.

Reassembly

Use new gaskets and reverse disassembly procedure. Note the following:

Choke Valve Installation - Install choke valve to marks made at disassembly, install valve screws finger-tight, then check valve for fit by rotating shaft through entire travel. If valve moves freely, close valve fully and tighten screws securely, stake screws while supporting shaft on metal bar.

Throttle Valve Installation - Install throttle valve to marks made at disassembly, install valve screws finger-tight, tap valve lightly while rotating shaft and check for free rotation. Check valve fit by holding carburetor up to a light (little or no light should show around edge of valve). When correct fit secured, close valve and tighten screws securely, stake screws while supporting shaft on metal bar.

